

# SWEEPER-S-HG

Sweeper-S-HG has a slim, elegant design and minimal occupied area while offering widest opening clearance to allow big boxes, trolley, wheelchair, baby stroller to pass through with comfort. At the same time full-height swing leaves guarantees a high level of security and a long service life. High leaves not only exclude the possibility of unauthorized passage, but also prevent of transferring anything above the turnstile, as well as over jumping it. The use of impact-resistant tempered glass guarantees safety and gives a sophisticated modern look.

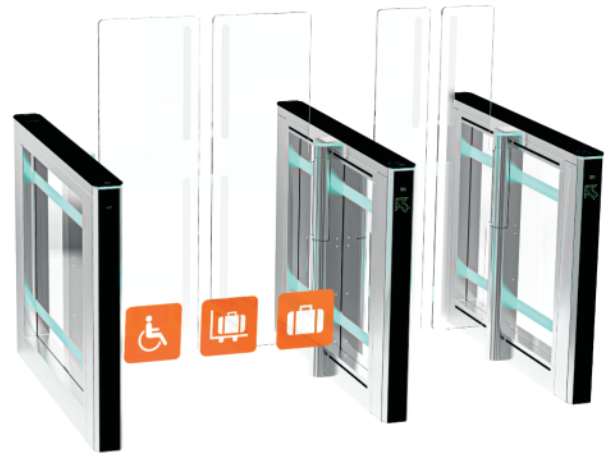

## SWEEPER-S-HG MODEL WITH HIGH LEAVES

HIGH LEVEL OF PROTECTION IN THE MOST COMPACT BODY



### Key features:

- BMDrive® - a reliable mechanism with a powerful BLDC gear motor ensures long-term, maintenance-free operation.
- The speed gate is equipped with a smart self-diagnostic system.
- An innovative controller with an OLED display and buttons allows for easy setup and configuration without the need for special programmers.
- Digital control of force and leaf speed, combined with safety sensors, prevents accidents and ensures the safety of individuals, even in cases of unauthorized passage.
- The sensor system enables the detection of individuals with luggage or allows for a free exit without the need for identification.
- Elegant cabinets come equipped with integrated LED lighting that displays the access status and card reader area.
- The housing design and top lid can be customized to meet specific preferences.
- Can be seamlessly integrated with any type of access control system.
- A wired remote control panel is included as part of the standard kit.
- Low power consumption.
- In the event of a power failure, the leaves can be manually opened (fail-safe).



# TECHNICAL SPECIFICATIONS

Model	Sweeper-S-HG 550	Sweeper-S-HG 900
Cabinet width, mm		174
Cabinet length, mm		1334
Cabinet height, mm		1010
Leaves height, mm		1500/1800
Passage width, mm	550	900
Opening/closing time, sec	0,6	0,8
Mechanism	BMDrive® servodrive (BLDC)	
Blocking system	ToothLock®	
Emergency mode (fire-alarm)	Free entry/exit (leaves are opened automatically)	
Power fail	Fail safe (gates could be opened manually — standard)	
MCBF, cycles	10 000 000	
MTTR, min	< 25	

## Electrical Specifications:

Maximum power consumption, W	160
Voltage	From the AC (100-240)V, 50/60Hz; from a DC source 12 V
Indication	DotLights®, RFIDLights®, EdgeLights®

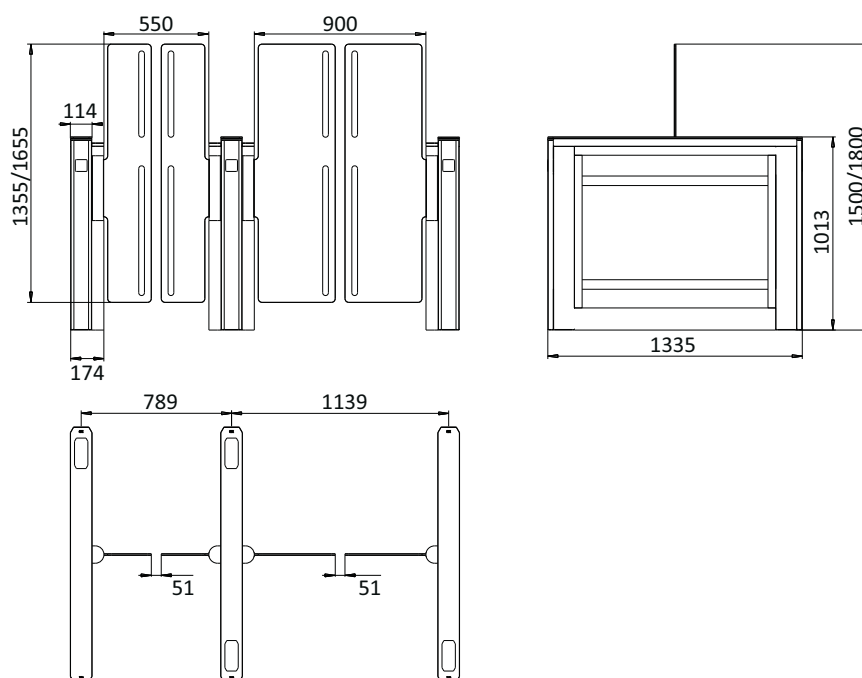

## Finishing

Standard housing	Brushed SS AISI 304
Available housing	Brushed SS AISI 316; Polished SS AISI 304; Polished SS AISI 316; Powder coated RAL



Specifications are subject to change without prior notice



 [www.tiso.global](http://www.tiso.global)  
 +380 (44) 291-21-11  
 [sales@tiso.global](mailto:sales@tiso.global)



# STANDARD FEATURES



## LED INDICATIONS

Introducing our RFIDLight® and DotLight® features, designed to captivate attention and enhance user experience:

RFIDLight®: Illuminates card reader area.  
DotLight®: Displays access status.



## CONTROL PANEL

Included in the standard set, our wired control panel offers versatile functionality: Facilitates single passage and free passage modes. Enables access blocking and activation of the anti-panic function.



## SAFETY SENSORS, ANTI-TAILGATING FUNCTION

Our high-precision sensors excel in identifying unauthorized passage, effectively preventing tailgating by detecting two or more individuals. Additionally, our safety sensors ensure secure passage for individuals with luggage or trolleys, ensuring gates remain open until the passage is completed.



## UPS FUNCTION

Introducing our advanced UPS system, seamlessly integrated to automatically switch power to the backup battery during outages. This ensures uninterrupted functionality of our speed gate, empowering you to utilize all features even in the event of a power failure.



## EDGELIGHTS®

Impressive illumination of the glass housing can be in three colors (standard), marking the status of passage: blue - standby mode; green - access authorized; red - access denied.



## PLACE FOR RFID INSTALLATION

RFID installation space included in standard speedgate configuration.



[www.tiso.global](http://www.tiso.global)

+380 (44) 291-21-11

[sales@tiso.global](mailto:sales@tiso.global)



# ADDITIONAL OPTIONS /

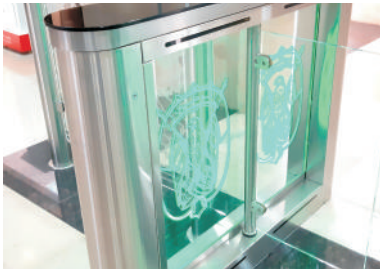

## PATTERN APPLICATION

Customize your speed gates with unique signatures, patterns, logos, and more, seamlessly placed on the leaves, housing, or top lid for a distinctive touch.



## MP3 AUDIO MODULE

Enjoy a comprehensive audio signaling system for various gate events: access / authorised access / closing / opening / alarm.

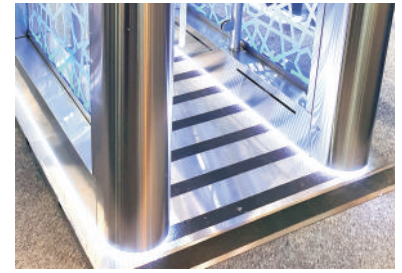

## FOOTPRINT ILLUMINATION

Illuminate the footprint of the speed gate housing with LED lighting. Customize the color of the light to suit your preferences.



## INTEGRATION OF CUSTOMISED ACS

Seamless integration of various access control systems upon request, including RFID devices, coin acceptor push buttons, fingerprint scanners, face recognition, barcode readers, and QR code readers.

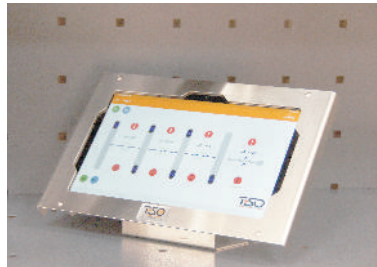

## TWIC WIRELESS CONTROL PANEL

TiSO TWIC offers remote control for multiple lines of turnstiles. With its space-saving 10" touchscreen display, it can be conveniently placed at reception desks or within security control areas.



## SUPER CAPASITOR

Ensure uninterrupted operation with our free power package, enabling emergency automatic one-time opening of the speed gate.



## CARD COLLECTOR INTEGRATION

Integration of automatic card collector directly into the speed gate housing is possible.



## PASS COUNTER

Automatically counts the number of passes for efficient tracking and management.



## EXIT BUTTON

Introducing a convenient touch-free button option for organizing exits effortlessly.

# ADDITIONAL OPTIONS

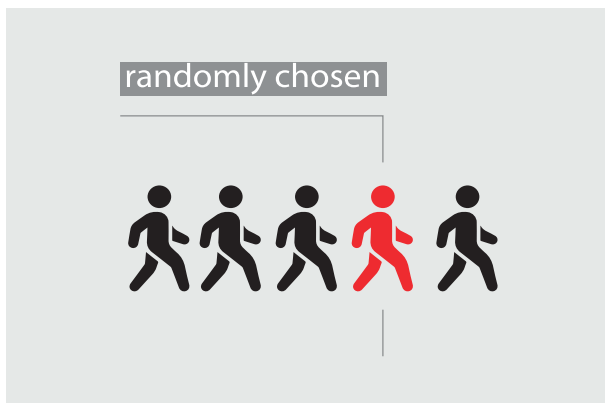

## RANDOMISER

This mechanism autonomously selects individuals for verification without human intervention, ensuring impartiality.



## RFID READERS T-PROX MINI

The reader is compatible with 125 kHz cards, Mifare, Mifare Plus, as well as mobile credentials U-Prox ID via NFC and 2.4 GHz radio.

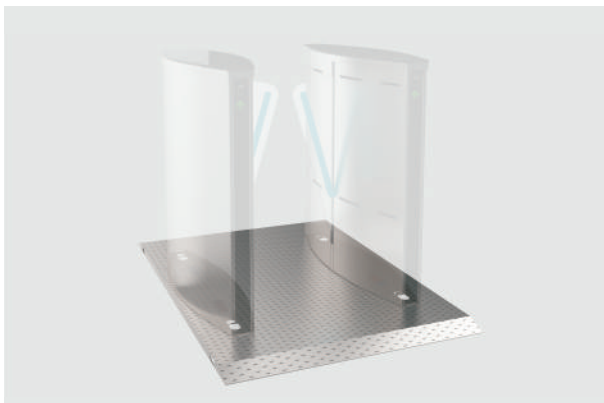

## MOBILE PLATFORM

Enables rapid temporary installation of the speed gate, ideal for areas where floor drilling is not possible.



## ALARM BUZZER

Audible alarm activated upon unauthorized access.